

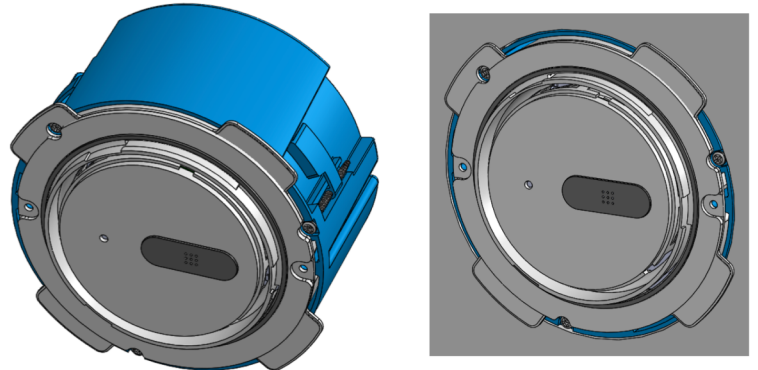

## February 2020

Remember this number: 10559179. This is the very first patent that was issued on behalf of Orrigen and will be included on all devices to protect the Intellectual Property that we have created. What a way to kick off 2020!

The internal Orrigen team just wrapped up its 2020 planning and is intending to complete the following items this year:



- 🔩 Complete UL certification
- 🔩 File patents in non US-based countries
- 🔩 Move from LLC to a Corporation
- 🔩 Convert issued agreements to Series A based on the next round of funding
- 🔩 Hire full time staff based on the needs of the company – a ramp up schedule is being prepared with cashflow being the number one priority
- 🔩 Attend next-step meetings with companies that expressed early interest to understand their intent
- 🔩 Develop the application based on the evolving use cases and finalize the architecture
- 🔩 Sign our first contracts with the home builders we have been negotiating with
- 🔩 Finalize our manufacturing costs and locations for the first run of product
- 🔩 Organize 2020 in-person town halls; we're coming to a city near you to personally thank you for your interest and investment in this emerging business!

Our mechanical and industrial engineers have further refined the housing of the product to be even more flush to the drywall than the original design. Additional testing is being completed on the configuration for the LED ring to determine the best design for light output. Electrically, our engineers have created our own smoke box to collect the data that allows us to write our own smoke detection algorithms. The electrical engineering team is collecting substantial data that will lead us to a successful certification meeting at UL. They are committed to returning to UL as soon as possible.

We have established lofty audacious goals to accomplish moving from a development platform to a pre-revenue company and then to a post-revenue company. As always, thank you for being along for the ride – we are so grateful for your support as we continue to press forward!

# Contact Us



Macie Walker, Chief Executive Officer

[Macie@orrigen.com](mailto:Macie@orrigen.com)



Mike Orr, Chief Technology Officer

[Mike@orrigen.com](mailto:Mike@orrigen.com)

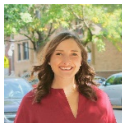

Briana George | Managing Partner,  
Administration

[Briana@orrigen.com](mailto:Briana@orrigen.com)



Mason Orr | Managing Partner, Business  
Development - Commercial

[Mason@orrigen.com](mailto:Mason@orrigen.com)

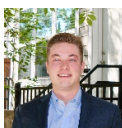

Andrew Kitch | Managing Partner, Business  
Development - Residential

[Andrew@orrigen.com](mailto:Andrew@orrigen.com)

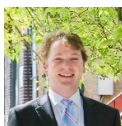

Austin Chew | Managing Partner,  
Operations

[Austin@orrigen.com](mailto:Austin@orrigen.com)